

Open impeller centrifugal electric pumps and threaded connections

CO-COM Series



MARKET SECTORS
CIVIL, INDUSTRIAL.

APPLICATIONS

- Washing of metal parts and/or surface treatment.
- Washing of produce in the packaging industry.
- Food industry washing equipment and systems.
- Dyeing plant and textile industry.
- Plants for the circulation and transfer of moderately viscous liquids, with light chemical aggressiveness.
- Industrial washing machines and commercial dishwashers.

CONSTRUCTION FEATURES

- Close-coupled, single-impeller centrifugal pump with axial suction and radial delivery.
- Threaded suction and delivery ports (Rp ISO 7).
- Compact construction; adaptor for motor/pump coupling; the impeller is keyed directly to the motor shaft extension.
- Back pull-out design; no need to disconnect the pump body from the system pipes.
- **AISI 316L** stainless steel open **impeller** with four pressed vanes welded onto base disk.
- Impeller's front **wear surface** consists of a study **AISI 316L** stainless steel plate welded onto the suction port.
- **AISI 316L** stainless steel **pump body and seal housing disk**, with no diffusers or cavities for easier cleaning and maintenance.
- Pump body tightened by 8 screws allowing rotation of the discharge head.
- **Mechanical seal:**
Standard version: Carbon/Ceramica faces, **FPM** elastomers. The other parts are made of AISI 316L stainless steel.
"K" version : faces are made of **Silicon Carbide and Tungsten Carbide. FPM** Elastomers. The other parts are made of AISI 316L stainless steel.
- **FPM O-Rings.**

SPECIFICATIONS PUMP

- **Delivery** up to 900 l/min (54 m³/h).
- **Head** up to 24 m.
- **Temperature** of pumped liquid: -10°C to +110°C for standard version.
- Maximum working **pressure** : 8 bar (PN 8).
- **Suspended solids** handled up to:
CO350: 11 mm.
CO500: 20 mm.

MOTOR

- Asynchronous, squirrel cage rotor, enclosed construction in aluminium casing, external ventilation.
- **Protection:** IP55.
- Class 155 (F) **insulation.**
- Performances according to EN 60034-1.
- Maximum ambient **temperature:** 40°C.
- **Standard voltage:**
- **Single-phase** version: 220-240 V 50 Hz, 2 poles with built-in automatic reset overload protection up to 1,5 kW. For higher powers the protection must be provided by the user.
- **Three-phase** version: 220-240/380-415 V 50 Hz, 2 poles; overload protection to be provided by the user.
- Condensate drain plugs on all motors.

☐ **All components in contact with pumped liquid are made of AISI 316L stainless steel**

☐ **Mechanical seal made of Silicon carbide/tungsten carbide/FPM in the "K" version**

OPTIONAL FEATURES

- Different voltages and frequencies.
- Different materials for the mechanical seal and O-rings.

CO - COM SERIES IDENTIFICATION CODE

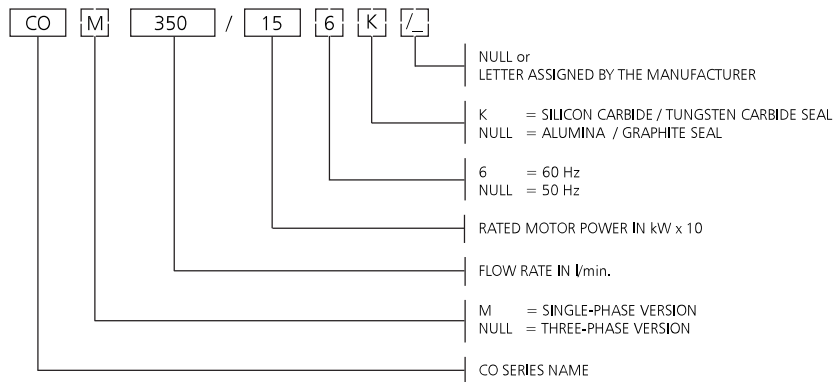

EXAMPLE : COM 350/156K
 CO series electric pump, single-phase, flow rate 350 l/min,
 rated power 1,5 kW, 60 Hz version, Silicon Carbide / Tungsten Carbide seal.

RATING PLATE

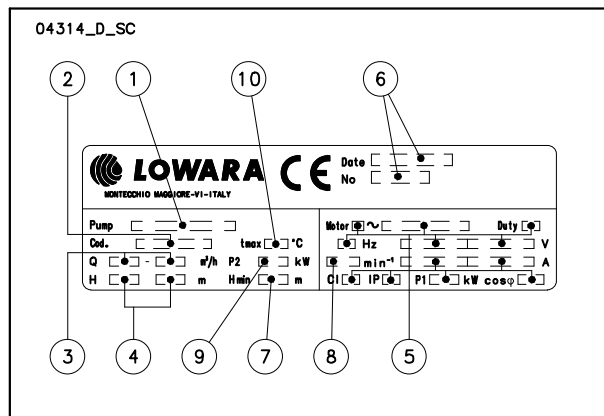

LEGEND

- 1 - Electric pump type
- 2 - Code
- 3 - Delivery range
- 4 - Head range
- 5 - Motor type
- 6 - Date of manufacture and serial number
- 7 - Minimum head
- 8 - Speed
- 9 - Rated output
- 10 - Maximum operating temperature

CO - COM SERIES LIST OF MODELS AND TABLE OF MATERIALS

04309_A_DS

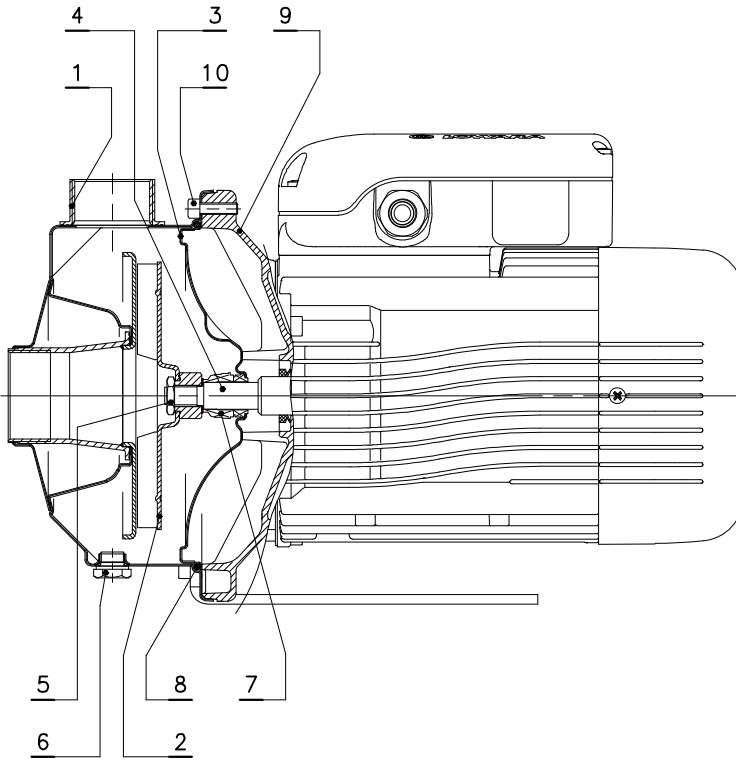

VERSIONS	
SINGLE-PHASE	THREE-PHASE
COM 350/03	CO 350/03
COM 350/05	CO 350/05
COM 350/07	CO 350/07
COM 350/09	CO 350/09
COM 350/11	CO 350/11
COM 350/15	CO 350/15
COM 500/15	CO 500/15
COM 500/22	CO 500/22
	CO 500/30

co-en_a_mo

REF. N.	NAME	MATERIAL	REFERENCE STANDARDS	
			EUROPE	USA
1	Pump body	Stainless steel	EN 10088-1-X2CrNiMo17-12-2 (1.4404)	AISI 316L
2	Impeller	Stainless steel	EN 10088-1-X2CrNiMo17-12-2 (1.4404)	AISI 316L
3	Seal housing	Stainless steel	EN 10088-1-X2CrNiMo17-12-2 (1.4404)	AISI 316L
4	Shaft extension	Stainless steel	EN 10088-1-X2CrNiMo17-12-2 (1.4404)	AISI 316L
5	Impeller locknut and washer	Stainless steel	EN 10088-1-X5CrNiMo17-12-2 (1.4401)	AISI 316
6	Fill/drain plugs	Stainless steel	EN 10088-1-X5CrNiMo17-12-2 (1.4401)	AISI 316
7	Mechanical seal	Ceramic / resin impregnated Carbon / FPM (standard version)		
8	Elastomers	FPM (standard version)		
9	Adapter	Aluminium	EN 1706-AC-AlSi11Cu2(Fe)DF	ASTM Class 25
10	Pump body fastening bolts & screws	Galvanized steel		

co-en_a_tm

CO - COM SERIES MECHANICAL SEAL

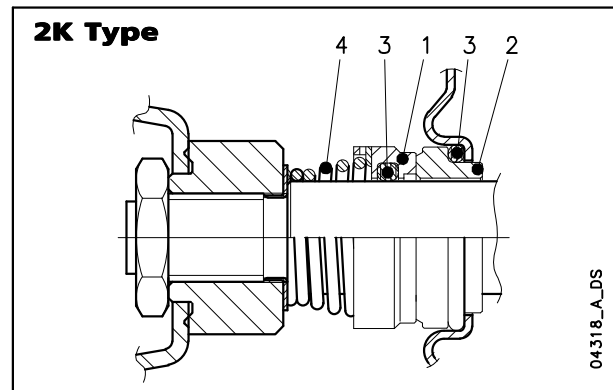
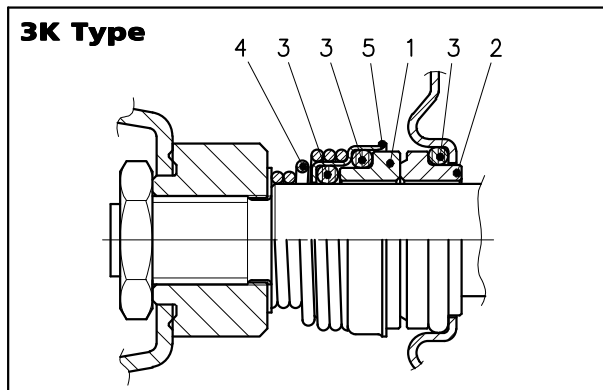

04318_A_DS

LIST OF MATERIALS

POSITION 1 - 2	POSITION 3	POSITION 4 - 5
B : Resin impregnated carbon	E : EPDM	G : AISI 316
C : Special resin impregnated carbon	V : FPM	
V : Ceramic		
Q₁ : Silicon Carbide		
U₃ : Tungsten Carbide		

SEAL TYPES

co_ten-mec-3-en_a_tm

TYPE	POSITION					TEMPERATURE (°C)
	1 ROTATING ASSEMBLY	2 FIXED ASSEMBLY	3 ELASTOMERS	4 SPRINGS	5 OTHER COMPONENTS	
STANDARD MECHANICAL SEAL						
3K - VB V G G	V	B	V	G	G	-10 +110
OTHER MECHANICAL SEAL TYPES						
3K - VC V G G	V	C	V	G	G	-10 +110
3K - Q₁CVGG	Q ₁	C	V	G	G	-10 +110
3K - Q₁Q₁VGG	Q ₁	Q ₁	V	G	G	-10 +110
2K - U₃Q₁VGG	U ₃	Q ₁	V	G	G	-10 +110
2K - U₃U₃VGG *	U ₃	U ₃	V	G	G	-10 +110
3K - VBEGG	V	B	E	G	G	-30 +110
3K - VCEGG	V	C	E	G	G	-30 +110
3K - Q₁CEGG	Q ₁	C	E	G	G	-30 +110
3K - Q₁Q₁EGG	Q ₁	Q ₁	E	G	G	-30 +110
2K - U₃Q₁EGG	U ₃	Q ₁	E	G	G	-30 +110
2K - U₃U₃EGG *	U ₃	U ₃	E	G	G	-30 +110

* Version with anti-rotation lockpin available on request.

co_tipi-ten-mec-3-en_b_tc

COMPLETE PUMP PRESSURE / TEMPERATURE OPERATING LIMITS (WITH ANY OF THE SEALS LISTED ABOVE)

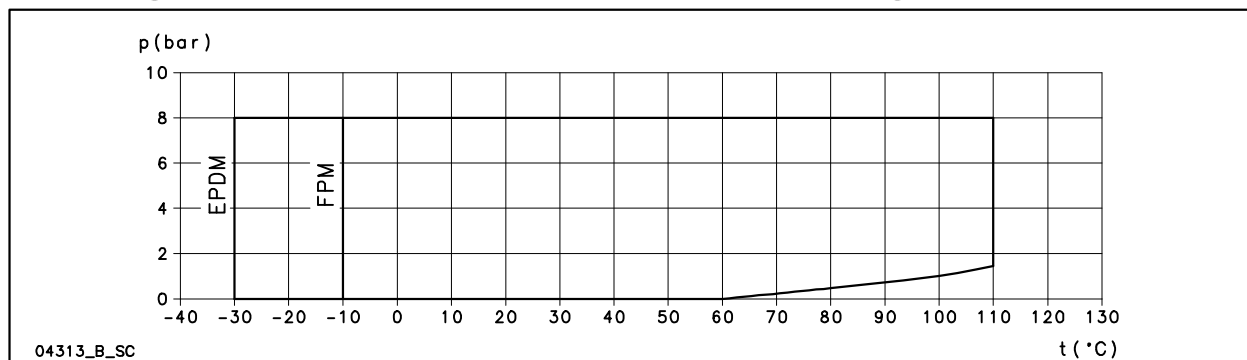

CO - COM SERIES HYDRAULIC PERFORMANCE RANGE AT 50 Hz, 2 POLES

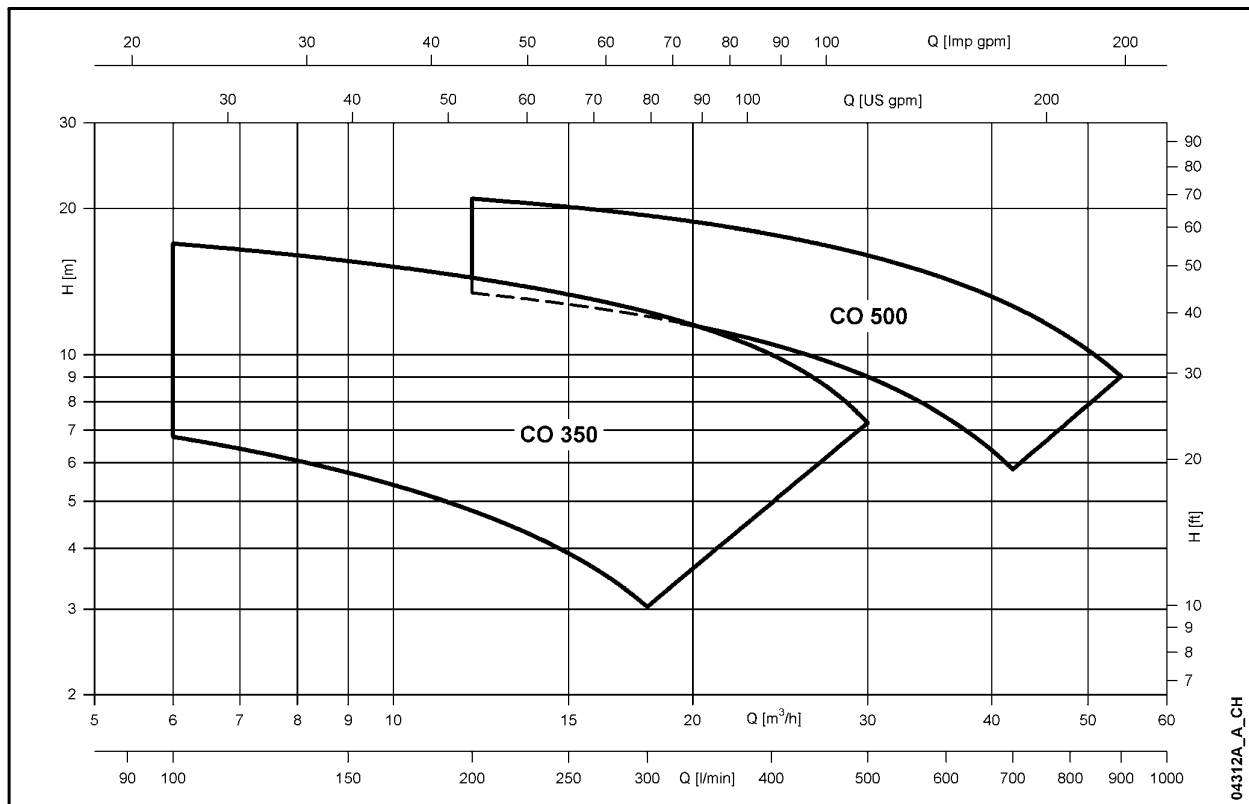

TABLE OF HYDRAULIC PERFORMANCES AT 50 Hz, 2 POLES

ELECTRIC PUMP TYPE	RATED POWER		Q = DELIVERY																	
			l/min	100	120	160	200	240	280	300	350	375	400	450	500	600	650	700	800	900
			m³/h	6	7,2	9,6	12	14,4	16,8	18	21	22,5	24	27	30	36	39	42	48	54
			H = TOTAL HEAD METRES COLUMN OF WATER																	
CO(M) 350/03	0,37	0,5	9,5	6,8	6,3	5,5	4,8	4,1	3,4	3,0										
CO(M) 350/05	0,55	0,75	12,0	9,2	8,8	7,9	7,1	6,3	5,5	5,1	4,0									
CO(M) 350/07	0,75	1	13,7	11,2	10,8	9,9	9,1	8,2	7,4	6,9	5,8	5,3								
CO(M) 350/09	0,9	1,2	15,7	12,7	12,2	11,3	10,5	9,6	8,8	8,3	7,2	6,6	5,9							
CO(M) 350/11	1,1	1,5	17,3	14,3	13,8	12,9	12,0	11,2	10,5	10,1	9,1	8,6	8,0	6,8						
CO(M) 350/15	1,5	2	20,3	16,9	16,4	15,3	14,4	13,5	12,7	12,2	11,2	10,6	10,0	8,7	7,2					
CO(M) 500/15	1,5	2	16,0				13,4	12,8	12,3	12,0	11,3	10,9	10,5	9,8	9,0	7,4	6,6	5,8		
CO(M) 500/22	2,2	3	19,6				17,3	16,7	16,2	15,9	15,2	14,9	14,5	13,7	13,0	11,3	10,4	9,6	7,7	
CO 500/30	3	4	24,1				20,9	20,3	19,7	19,3	18,5	18,1	17,7	16,9	16,0	14,3	13,5	12,6	10,8	9,0

co-2p50-en_d_th

PUMP TYPE	MOTOR TYPE	INPUT			PUMP TYPE	MOTOR TYPE	INPUT		
		POWER*	CURRENT*	CAPACIT.			POWER*	CURRENT*	CURRENT*
1 ~		kW	220-240 V A	µF / 450 V	3 ~		kW	220-240 V A	380-415 V A
COM350/03	SM63BG/1045	0,63	2,82	14	CO350/03	SM63BG/304	0,64	2,53	1,46
COM350/05	SM71BG/1055	0,88	4,25	16	CO350/05	SM71BG/305	0,79	2,70	1,56
COM350/07	SM71BG/1075	1,02	4,67	20	CO350/07	SM80BG/307PE	0,92	2,96	1,71
COM350/09	SM71BG/1095	1,21	5,46	25	CO350/09	SM80BG/311PE	1,08	3,72	2,15
COM350/11	SM80BG/1115	1,75	7,85	30	CO350/11	SM80BG/311PE	1,61	4,87	2,81
COM350/15	SM80BG/1155	2,04	9,21	40	CO350/15	SM80BG/315PE	1,87	5,75	3,32
COM500/15	SM80BG/1155	2,02	9,12	40	CO500/15	SM80BG/315PE	1,84	5,70	3,29
COM500/22	PLM90BG/1225	2,72	12,7	70	CO500/22	PLM90BG/322	2,66	8,27	4,78
-	-	-	-	-	CO500/30	PLM90BG/330	3,80	11,4	6,57

*Maximum value in specified range.

co-2p50-en_f_te

MOTORS FOR CO SERIES

Standard supplied IE2/IE3 three-phase surface motors $\geq 0,75$ kW are compliant with Regulation (EC) no. 640/2009 and IEC 60034-30.

Electrical performances according to EN 60034-1.

Insulation class 155 (F). IP55 protection. Condensate drain plugs on standard version.

Cooling by fan according to EN 60034-6.

Cable gland metric size according to EN 50262. Standard voltage:

- **Single-phase** version: 220-240 V 50 Hz (incorporated automatic-reset overload protection).
- **Three-phase** version: 220-240/380-415 V 50 Hz (overload protection to be provided by the user).

SINGLE-PHASE MOTORS AT 50 Hz, 2 POLES

P _N kW	MOTOR TYPE	IEC SIZE	Construction Design	INPUT	CAPACITOR		DATA FOR 230 V 50 Hz VOLTAGE						
				CURRENT	μ F	V	min ⁻¹	I _s / I _N	η %	cos ϕ	T _N Nm	T _s /T _N	T _m /T _N
				I _N (A)									
0,4	SM63BG/1045	63	SPECIAL	2,79-2,85	14	450	2745	2,64	65,1	0,96	1,39	0,68	1,63
0,55	SM71BG/1055	71		3,76-3,99	16	450	2820	3,72	68,9	0,91	1,86	0,61	2,00
0,75	SM71BG/1075	71		4,90-4,85	20	450	2765	3,42	70,1	0,96	2,59	0,58	1,75
0,95	SM71BG/1095	71		6,25-5,89	25	450	2740	3,39	71,1	0,98	3,31	0,58	1,66
1,1	SM80BG/1115	80		6,88-6,65	30	450	2800	3,89	74,7	0,96	3,75	0,46	1,72
1,5	SM80BG/1155	80		9,21-8,58	40	450	2810	4,00	76,1	0,98	5,09	0,39	1,74
2,2	PLM80BG/1225	90		12,5-11,6	70	450	2825	4,47	82,4	0,97	7,43	0,53	1,87

THREE-PHASE MOTORS AT 50 Hz, 2 POLES

co-motm-2p50-en_a_te

P _N kW	Efficiency η_N																		Year of manufacture		
	%																				
	Δ 220 V Y 380 V			Δ 230 V Y 400 V			Δ 240 V Y 415 V			Δ 380 V Y 660 V			Δ 400 V Y 690 V			Δ 415 V				IE	
4/4	3/4	2/4	4/4	3/4	2/4	4/4	3/4	2/4	4/4	3/4	2/4	4/4	3/4	2/4	4/4	3/4	2/4				
0,4	-	-	-	-	-	-	-	-	-	-	-	-	-	-	-	-	-	-	-	-	By June 2011
0,55	-	-	-	-	-	-	-	-	-	-	-	-	-	-	-	-	-	-	-	-	
0,75	82,5	83,1	81,3	82,8	82,7	80,1	82,6	82,0	78,9	82,5	82,0	78,9	82,5	82,0	78,9	82,5	82,0	78,9	3		
0,9	84,0	84,7	83,4	84,4	84,5	82,5	84,3	84,0	81,4	84,0	84,0	81,4	84,0	84,0	81,4	84,0	84,0	81,4	3		
1,1	84,0	84,7	83,4	84,4	84,5	82,5	84,3	84,0	81,4	84,0	84,0	81,4	84,0	84,0	81,4	84,0	84,0	81,4	3		
1,5	85,6	86,5	85,8	85,9	86,4	84,9	86,0	86,0	84,0	85,6	86,0	84,0	85,6	86,0	84,0	85,6	86,0	84,0	3		
2,2	83,7	83,7	83,7	83,7	83,7	83,7	83,7	83,7	83,7	83,7	83,7	83,7	83,7	83,7	83,7	83,7	83,7	83,7	3		
3	85,5	86,8	85,6	86,1	86,8	85,6	86,3	86,8	85,6	85,5	86,8	85,6	85,5	86,8	85,6	85,5	86,8	85,6	2		

P _N kW	Manufacturer		IEC SIZE	Construction Design	N. of Poles	f _N Hz	Data for 400 V / 50 Hz Voltage				
	Lowara srl Unipersonale Reg. No. 341820260 Montecchio Maggiore Vicenza - Italia						cos ϕ	I _s / I _N	T _N Nm	T _s /T _N	T _m /T _N
	Model										
0,4	SM63BG/304	63	SPECIAL	2	50	0,66	4,32	1,38	4,14	3,13	
0,55	SM71BG/305	71				0,74	5,97	1,85	3,74	3,56	
0,75	SM80BG/307PE	80				0,78	7,38	2,48	3,57	3,75	
0,9	SM80BG/311PE	80				0,79	8,31	3,63	3,95	3,95	
1,1	SM80BG/311PE	80				0,79	8,31	3,63	3,95	3,95	
1,5	SM80BG/315PE	80				0,80	8,80	4,96	4,31	4,10	
2,2	PLM90BG/322	90				0,80	8,63	7,25	3,74	3,71	
3	PLM90BG/330	90				0,82	8,39	9,96	3,50	3,32	

P _N kW	Voltage U _N V										η_N min ⁻¹	Operating conditions **				
	Δ			Y			Δ			Y			Altitude Above Sea Level (m)	T. amb min/max °C	ATEX	
	220 V	230 V	240 V	380 V	400 V	415 V	380 V	400 V	415 V	660 V		690 V				
0,4	2,20	2,34	2,51	1,27	1,35	1,45	-	-	-	-	-	2740 ÷ 2790	See note.	≤ 1000	-15 / 40	No
0,55	2,56	2,56	2,62	1,48	1,48	1,51	-	-	-	-	-	2825 ÷ 2850				
0,75	2,96	2,94	2,96	1,71	1,70	1,71	1,70	1,69	1,70	0,98	0,98	2875 ÷ 2895				
0,9	4,19	4,14	4,16	2,42	2,39	2,40	2,41	2,38	2,38	1,39	1,37	2870 ÷ 2900				
1,1	4,19	4,14	4,16	2,42	2,39	2,40	2,41	2,38	2,38	1,39	1,37	2870 ÷ 2900				
1,5	5,56	5,49	5,51	3,21	3,17	3,18	3,21	3,18	3,19	1,85	1,84	2870 ÷ 2895				
2,2	8,05	8,04	8,09	4,65	4,64	4,67	4,62	4,61	4,63	2,67	2,66	2885 ÷ 2900				
3	10,8	10,6	10,6	6,23	6,14	6,12	6,18	6,10	6,06	3,57	3,52	2850 ÷ 2885				

Note: Observe the regulations and codes locally in force regarding sorted waste disposal.

co-ie2-mott-2p50-en_b_te

** Operating conditions to be referred to motor only. About electric pump, refer to limits in user's manual.

AVAILABLE VOLTAGES MOTORS FOR CO SERIES

P _N kW	IEC SIZE	SINGLE-PHASE							
		50 Hz				60 Hz			
0,4	63	s	o	o	s	-	o	-	-
0,55	71	s	o	o	s	o	o	o	o
0,75	71	s	o	o	s	o	o	o	o
0,95	71	s	o	o	s	o	o	o	o
1,1	80	s	-	o	s	-	o	-	o
1,5	80	s	-	-	s	-	o	-	o
2,2	90	s	-	-	s	-	-	-	-

s = Standard voltage o = Optional voltage

P _N kW	THREE-PHASE - 2 POLES												
	50 Hz						60 Hz				50/60 Hz		
0,4	s	o	o	o	o	o	s	o	o	o	o	o	o
0,55	s	o	o	o	o	o	s	o	o	o	o	o	o
0,75	s	o	o	o	o	o	s	o	o	o	o	o	o
0,95	s	o	o	o	o	o	s	o	o	o	o	o	o
1,1	s	o	o	o	o	o	s	o	o	o	o	o	o
1,5	s	o	o	o	o	o	s	o	o	o	o	o	o
2,2	s	o	o	o	o	o	s	o	o	o	o	o	o
3	s	o	o	o	o	o	s	o	o	o	o	o	o

- = Not available

co-volt-low-a-en_a_te

**CO350 SERIES
OPERATING CHARACTERISTICS AT 50 Hz, 2 POLES**

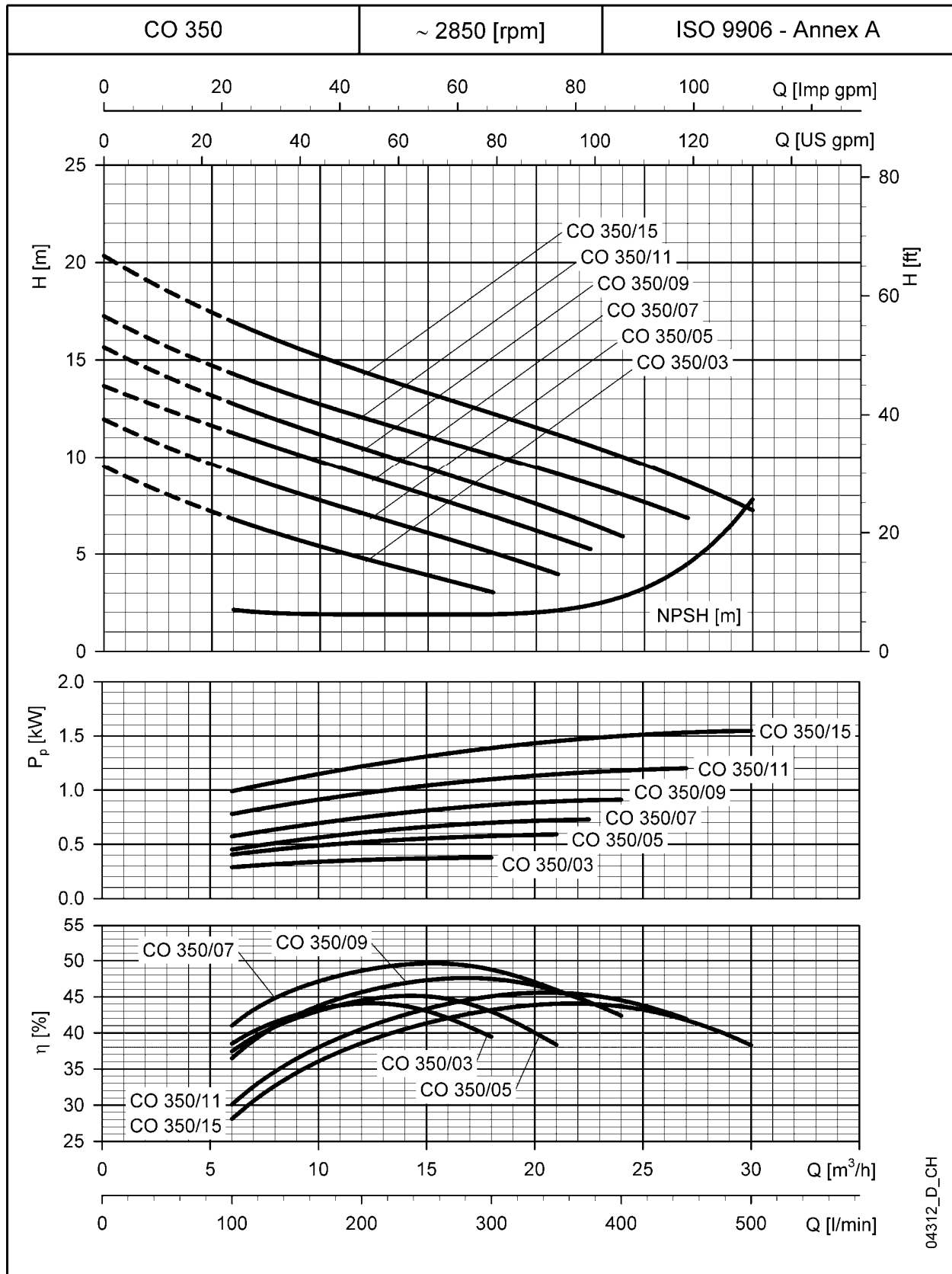

The NPSH values are laboratory values: for practical use we suggest increasing these values by 0,5 m.
These performances are valid for liquids with density $\rho = 1.0 \text{ Kg/dm}^3$ and kinematic viscosity $\nu = 1 \text{ mm}^2/\text{sec}$.

**CO500 SERIES
OPERATING CHARACTERISTICS AT 50 Hz, 2 POLES**

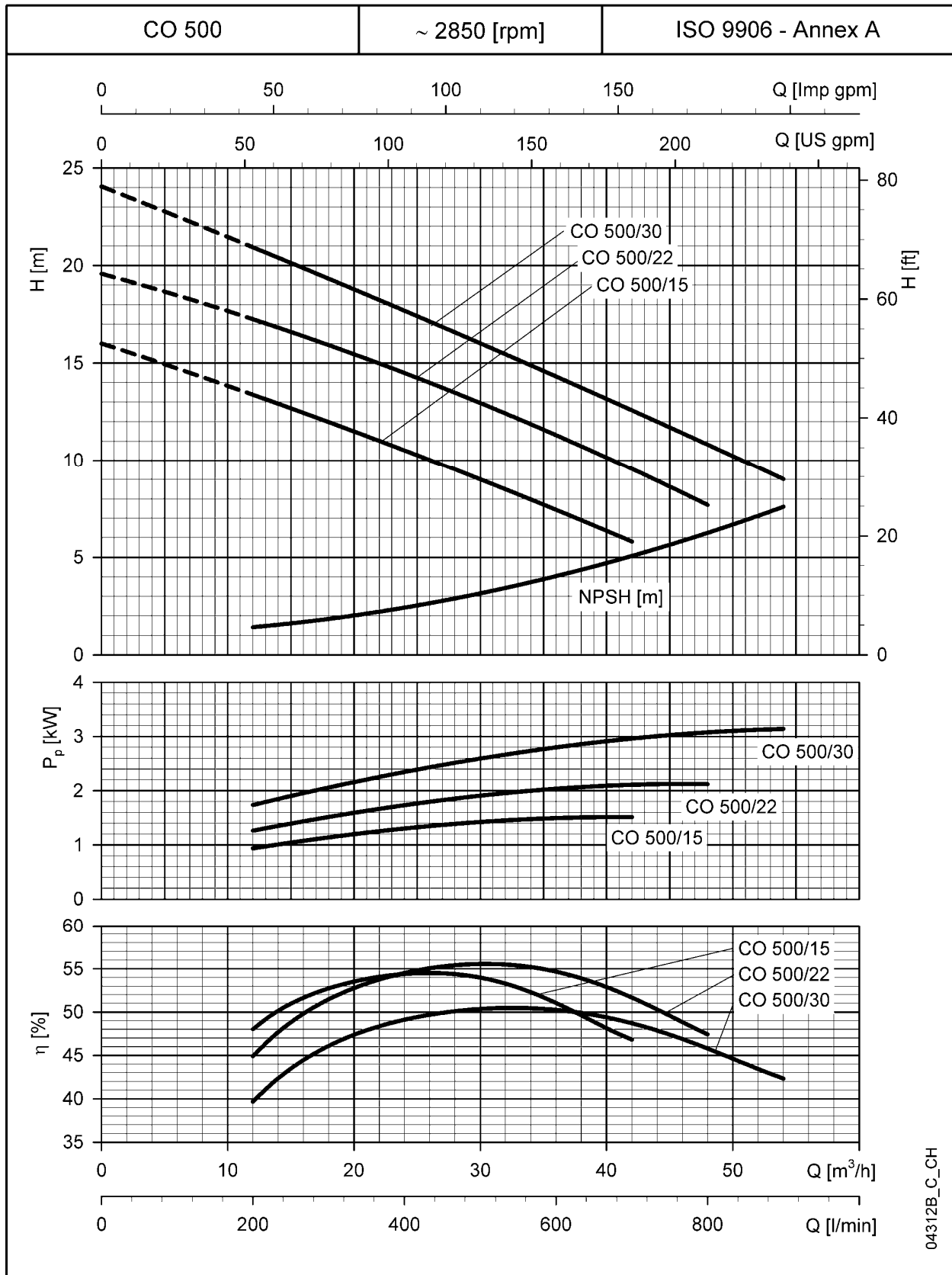

The NPSH values are laboratory values: for practical use we suggest increasing these values by 0,5 m.
These performances are valid for liquids with density $\rho = 1.0 \text{ Kg/dm}^3$ and kinematic viscosity $\nu = 1 \text{ mm}^2/\text{sec}$.

CO SERIES DIMENSIONS AND WEIGHTS AT 50 Hz, 2 POLES

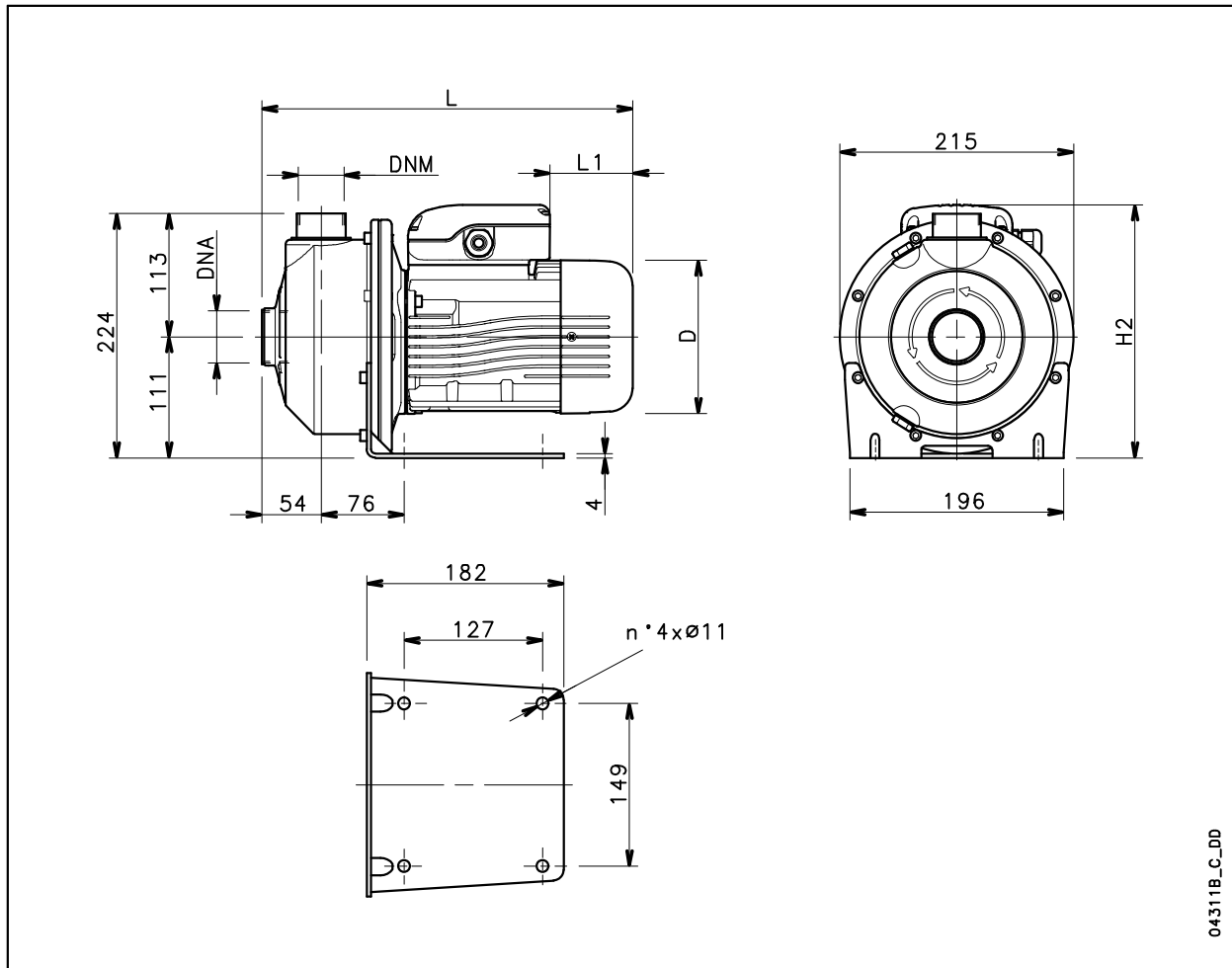

PUMP TYPE	DIMENSIONS (mm)				DNA	DNM	WEIGHT kg
	D	H2	L	L1			
COM 350/03/A	120	222	325	62	Rp 1½	Rp ¼	10
COM 350/05/A	140	232	339	76	Rp 1½	Rp ¼	11,9
COM 350/07/A	140	232	339	76	Rp 1½	Rp ¼	12,6
COM 350/09/A	140	241	339	31	Rp 1½	Rp ¼	13,2
COM 350/11/A	156	248	385	69	Rp 1½	Rp ¼	14,5
COM 350/15/A	156	248	385	69	Rp 1½	Rp ¼	16,2
COM 500/15/A	156	248	385	69	Rp 2	Rp ½	16,2
COM 500/22/P	174	262	429	84	Rp 2	Rp ½	20
CO 350/03/A	120	222	325	62	Rp 1½	Rp ¼	10
CO 350/05/A	140	232	339	76	Rp 1½	Rp ¼	11,9
CO 350/07/D	155	240	385	114	Rp 1½	Rp ¼	14,1
CO 350/09/D	155	240	385	114	Rp 1½	Rp ¼	16
CO 350/11/D	155	240	385	114	Rp 1½	Rp ¼	16,3
CO 350/15/D	155	240	385	114	Rp 1½	Rp ¼	17,8
CO 500/15/D	155	240	385	114	Rp 2	Rp ½	17,8
CO 500/22/C	174	245	429	172	Rp 2	Rp ½	23
CO 500/30/P	174	245	429	172	Rp 2	Rp ½	25