

Installation and Operation Instruction

The **FlowCon Green** inserts are for use with three different FlowCon valve housings, either:

- ① FlowCon A DN15-25 (1/2"-1")
- ② FlowCon AB DN15-32 (1/2"-1 1/4")
- ③ FlowCon ABV DN15-40 (1/2"-1 1/2")

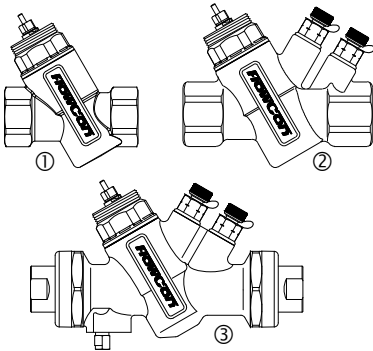

Insert Setting and Installation

Prior to installing the FlowCon Green insert (supplied from factory in setting 5.0 due to calibration), the system should be properly flushed. Blank valve covers are available to be installed during flushing.

It is recommended to grease the O-rings located around the insert and headnut with silicone grease before installing the insert in the valve housing.

General Assembly Drawing FlowCon Green

- A: Valve housing
- B: Green insert
- C: Adjustment keys
- D1: P/t plug (2 pcs.)
- D2: Plug (2 pcs.)
- E: Union end connections
- F: FlowCon actuator

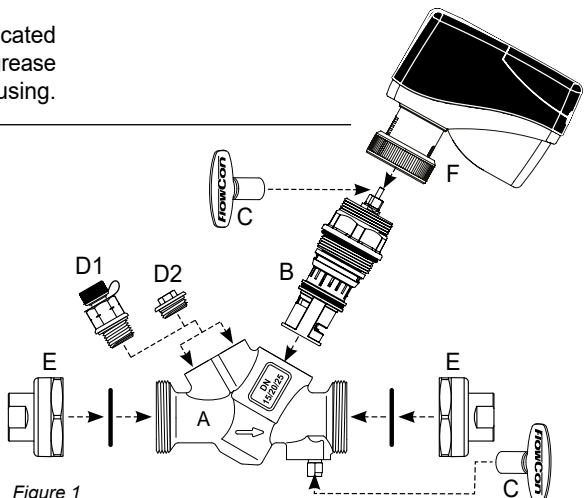
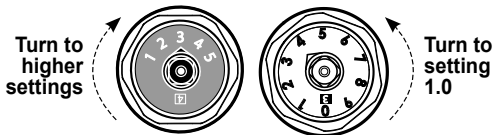

Figure 1

The desired flow rate is set by adjusting the insert (turn counter-clockwise to setting 1.0 and then clockwise up) with a special adjustment key. **Range is between 1.0 and 5.0.**

⚠ Do not overturn.

Scale setting is located on top of the insert. For Green.0, Green.1 and Green.2, large white digits, numbered 1 to 5, indicate full turns and red digits, numbered 0 to 9, indicate 1/10 of full turn. **For Green.1HF scale is opposite.** Here large green digits, numbered 0 to 9, indicate 1/10 of full turn and black digits, numbered 0 to 5, indicate full turn. Flow setting may be done either before or after the insert is installed in the valve housing. Once flow is set and insert is fitted in the valve housing, the required actuator may be applied. Please see specific installation instruction for selected actuator.



FlowCon Green 15-40 mm (1/2"-1 1/2")

1B95092 - 10/2021

A Griswold Controls LLC/FlowCon International Company

FlowCon Green														
Insert size: 20 mm · 3/4"											Insert size: 40 mm · 1 1/2"			Setting
16-600 kPaD · 2.3-87 psid ¹			30-800 kPaD · 4.4-116 psid ²			35-800 kPaD · 5.1-116 psid ²			16-800 kPaD · 2.3-116 psid (at setting 2.6)			Setting		
Green.0 (grey O-ring)			Green.1 (black O-ring)			Green.1HF (black O-ring)			Green.2 (black O-ring)					
I/sec	I/hr	GPM	I/sec	I/hr	GPM	I/sec	I/hr	GPM	I/sec	I/hr	GPM	Nominal flow rate		
-	-	-	0.0178	64	0.282	-	-	-	0.240	865	3.81		1.0	
0.0103	37	0.163	0.0393	142	0.624	-	-	-	0.282	1010	4.46		1.1	
0.0233	84	0.370	0.0580	209	0.920	-	-	-	0.322	1160	5.10		1.2	
0.0322	116	0.510	0.0743	268	1.180	-	-	-	0.361	1300	5.72		1.3	
0.0419	151	0.664	0.0887	319	1.41	-	-	-	0.399	1430	6.32		1.4	
0.0500	180	0.792	0.102	366	1.61	0.172	620	2.73	0.435	1570	6.90		1.5	
0.0569	205	0.902	0.113	408	1.80	0.200	720	3.17	0.471	1700	7.47		1.6	
0.0650	234	1.03	0.124	446	1.96	0.228	820	3.61	0.506	1820	8.02		1.7	
0.0719	259	1.14	0.134	482	2.12	0.258	930	4.10	0.540	1940	8.56		1.8	
0.0781	281	1.24	0.143	516	2.27	0.294	1060	4.67	0.573	2060	9.08		1.9	
0.0839	302	1.33	0.152	549	2.42	0.325	1170	5.15	0.605	2180	9.59		2.0	
0.0889	320	1.41	0.161	580	2.56	0.350	1260	5.55	0.636	2290	10.1		2.1	
0.0942	339	1.49	0.170	611	2.69	0.375	1350	5.95	0.667	2400	10.6		2.2	
0.0981	353	1.55	0.178	641	2.82	0.396	1430	6.28	0.696	2510	11.0		2.3	
0.103	371	1.63	0.186	671	2.95	0.417	1500	6.61	0.725	2610	11.5		2.4	
0.106	381	1.68	0.194	700	3.08	0.439	1580	6.96	0.753	2710	11.9		2.5	
0.109	394	1.73	0.202	728	3.21	0.458	1650	7.27	0.780	2810	12.4		2.6	
0.113	406	1.79	0.210	756	3.33	0.481	1730	7.62	0.807	2900	12.8		2.7	
0.115	414	1.82	0.218	783	3.45	0.500	1800	7.93	0.832	3000	13.2		2.8	
0.119	428	1.88	0.225	810	3.56	0.522	1880	8.28	0.858	3090	13.6		2.9	
0.122	439	1.93	0.232	835	3.68	0.542	1950	8.59	0.882	3180	14.0		3.0	
0.125	449	1.98	0.239	860	3.79	0.550	1980	8.72	0.906	3260	14.4		3.1	
0.127	458	2.02	0.245	883	3.89	0.558	2010	8.85	0.930	3350	14.7		3.2	
0.130	468	2.06	0.252	906	3.99	0.567	2040	8.99	0.953	3430	15.1	3.3		
0.133	477	2.10	0.257	927	4.08	0.575	2070	9.12	0.975	3510	15.5	3.4		
0.135	486	2.14	0.263	946	4.17	0.583	2100	9.25	0.997	3590	15.8	3.5		
0.137	494	2.17	0.268	965	4.25	0.597	2150	9.47	1.02	3670	16.1	3.6		
0.140	503	2.21	0.273	982	4.32	0.611	2200	9.69	1.04	3740	16.5	3.7		
0.142	511	2.25	0.277	998	4.39	0.625	2250	9.91	1.06	3820	16.8	3.8		
0.144	518	2.28	0.281	1010	4.46	0.639	2300	10.1	1.08	3890	17.1	3.9		
0.146	526	2.31	0.285	1020	4.51	0.653	2350	10.4	1.10	3960	17.4	4.0		
0.148	532	2.34	0.288	1040	4.57	0.661	2380	10.5	1.12	4030	17.7	4.1		
0.149	538	2.37	0.291	1050	4.61	0.669	2410	10.6	1.14	4100	18.1	4.2		
0.151	544	2.39	0.294	1060	4.66	0.678	2440	10.7	1.16	4170	18.4	4.3		
0.153	549	2.42	0.296	1070	4.70	0.686	2470	10.9	1.18	4240	18.7	4.4		
0.154	553	2.43	0.299	1080	4.73	0.694	2500	11.0	1.20	4300	19.0	4.5		
0.155	559	2.46	0.301	1080	4.77	0.703	2530	11.1	1.21	4370	19.2	4.6		
0.156	563	2.48	0.303	1090	4.80	0.711	2560	11.3	1.23	4440	19.5	4.7		
0.158	567	2.50	0.305	1100	4.83	0.719	2590	11.4	1.25	4500	19.8	4.8		
0.159	571	2.51	0.307	1100	4.86	0.728	2620	11.5	1.27	4570	20.1	4.9		
0.160	575	2.53	0.308	1110	4.89	0.736	2650	11.7	1.29	4630	20.4	5.0		

Accuracy: Greatest of either ±10% of controlled flow rate or ±5% of maximum flow rate.

Note 1: If used in pressure range 200-600 kPaD (29-87 psid), accuracy of -20% / +0% applies.

Note 2: If used in pressure range 400-800 kPaD (58-116 psid), accuracy of -20% / +0% applies.

FlowCon International assumes no responsibility for mistakes, if any, in any printed material.