



 **LOWARA**
a xylem brand

e-SV Series

Vertical Multistage Pump

STAINLESS STEEL VERTICAL MULTI-STAGE PUMPS



Xylem is a leading water technology company committed to solving the world's water, wastewater, and energy needs by creating innovative and smart technology solutions. Their technological strength across the life cycle of water is second-to-none, from collection and distribution to reuse and return to nature. **Xylem's** highly efficient water technologies, pumps, and application solutions promote sustainability by using less energy and reducing life-cycle costs.



Ensavior is proudly associated as Channel partner with Xylem water Solutions. Our experienced team is equipped with the technical know-how to provide comprehensive support and product demonstrations to meet all your water, wastewater, and energy needs. Whether you have questions or require complete technical support, **Ensavior** is here to assist you every step of the way. Join forces with **Ensavior** and **Xylem** Water Solutions to create a sustainable future today!"

Hydraulic performance range

Easy to maintain

The e-SV's new design allows removal of the mechanical seal without having to remove the motor, reducing repair time by up to 50%. A standard DIN mechanical seal, wearing components, service tools and standard IEC motors enable faster and easier maintenance and servicing.

Energy saving

Pumps are among the largest users of industrial energy. Do your part to reduce CO₂ emissions and your impact on the environment - and improve your bottom line - by taking advantage of the new e-SV's lower energy requirement. Use a new e-SV pump along with a variable speed drive such as Xylem's Hydrovar®, and save even more energy and money.

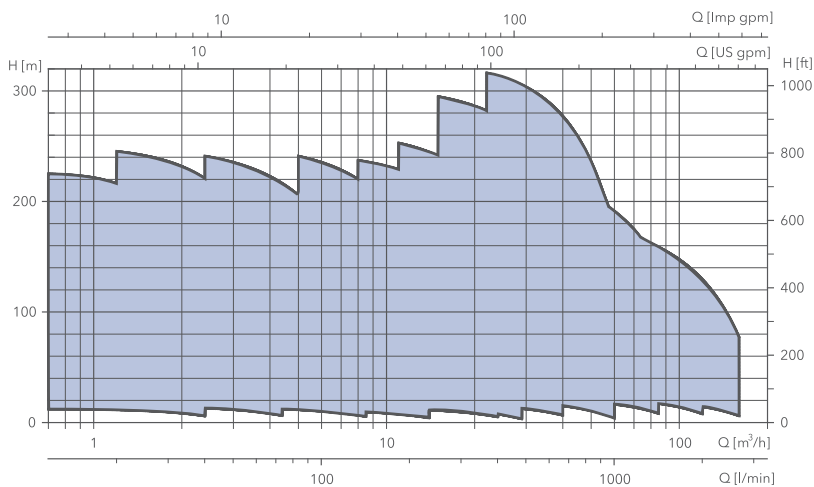

Benefits

The e-SV range of pumps features 11 models, and can be specially configured for a wider range of applications. The line is interchangeable with Lowara's SSV series of vertical multi-stage pumps for added flexibility in meeting pumping requirements. Additionally, five e-SV manufacturing facilities around the world provide shorter lead times and faster service.

Applications

- Water supply and pressure boosting
- Water treatment
- Light industry
- Irrigation and farming
- Heating, ventilation and air-conditioning

Specifications

Delivery	up to 160 m ³ /h
Head	up to 330 m
Power supply	three-phase and single-phase 50Hz
Power	standard motors from 0.37 kW to 55 kW
Maximum operating pressure	PN25-40 for sizes 1-22SV; PN16, PN25, PN40 for sizes 33-125
Temperature of pumped liquid	-30 °C to +120 °C
Protection	IP55
Insulation class F	F



Stainless steel vertical multi-stage pumps

Why "e"-SV? "e" stands for the ultimate in energy efficiency, easy installation and economical operation - a new generation of vertical, multi-stage pumps that deliver outstanding performance and reliability.

Developed based on intensive research into user needs, the new e-SV pumps are designed to extend uptime and help reduce lifecycle costs in a wide variety of demanding applications.



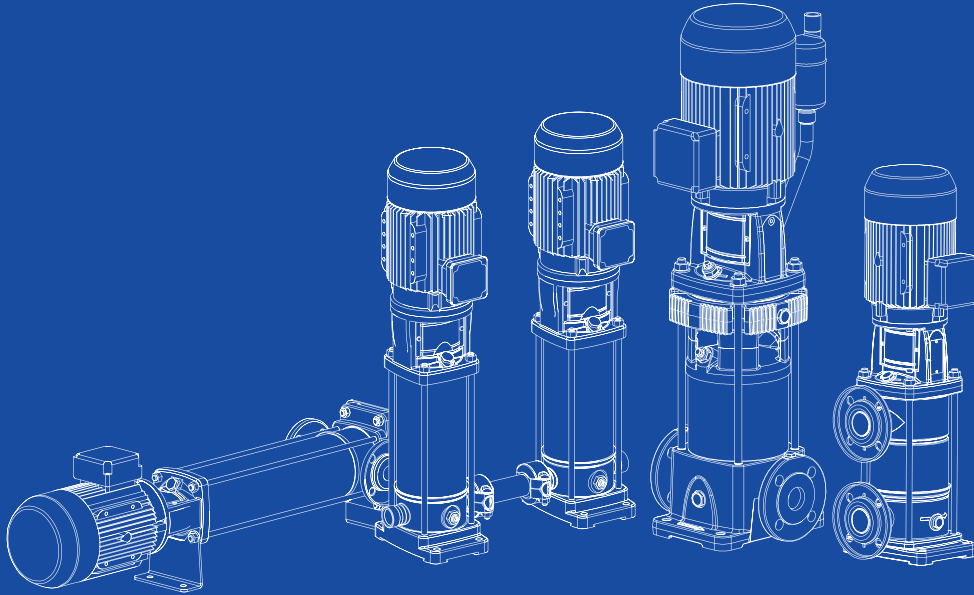

Special Versions

- e-SV™ - High Pressure - 50 Hz
- e-SV™ - Low NPSH - 50 Hz
- e-SV™ - High Temperature - 150 °C & 180 °C
- e-SV™ - With Hydrovar® - SVH
- e-SV™ - 4-pole version - 50 Hz
- e-SV™ - Reducing footprint - 50 Hz
- e-SV™ - Horizontal version - 50 Hz

Options Index

- Motor's configuration and standard options
- Dry-running sensor
- i-Alert device
- Tests and certifications
- Accessories



Ensavior Technologies Pvt. Ltd



+91- 9658 373 373
+91- 11- 47350382



Plot No. 17A, Block A, Sector 19, Dwarka,
New Delhi-110075, INDIA



info@ensavior.com
www.ensavior.com

Branch Offices: Bengaluru | Kolkata | Mumbai | Singapore

CIN: U72900DL2011PTC222724